

FLANGED BODY

Black-oxide steel.

PLUNGER

Hardened steel.

KNOB

High-resilience polyamide based (PA) technopolymer, black colour, matte finish.

FEATURES AND APPLICATIONS

GN 607.5 spring plungers are designed for fixing by means of welding, in particular for applications on square-section steel profiles.

These plungers are recommended for use where positioning operations are required and in those applications where the plunger needs to be locked in the retracted position.

The knurled knob should be assembled to the flanged body after the welding operation to prevent damaging the plastic material.

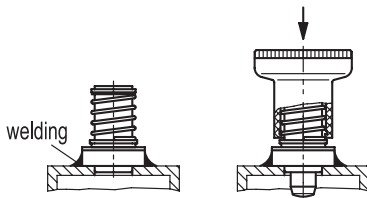

To prevent damaging the plastic material, the handle should be assembled after welding the flanged body by means of a plastic mallet.

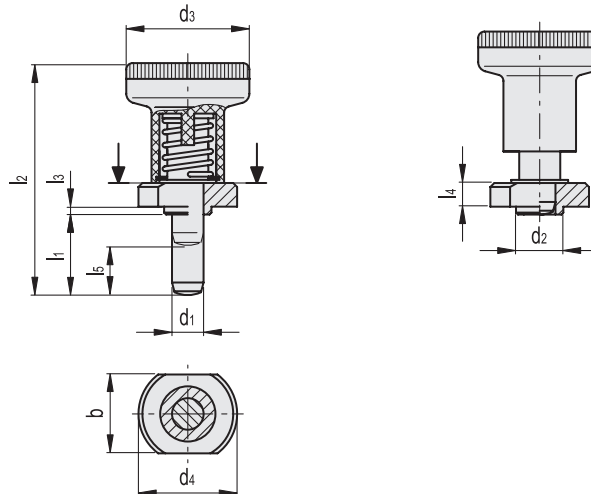

Code	Description	d1										Spring preload [N]	Spring max load [N]	Axial holding force [N]	⚖	
		Plunger -0.02	d2 -0.02 -0.1	d3	d4	b	l1	l2	l3	l4	l5					
GN.34721	GN 607.5-6-6-ST	Hole +0.30 +0.25	6	10	25	22	18	6	37	1.5	5.5	6	8.5	22	400	40
GN.34723	GN 607.5-6-14-ST		6	10	25	22	18	14	45	1.5	5.5	6	8.5	22	400	36
GN.34725	GN 607.5-8-8-ST		8	12	31	25	20	8	44	2	6.5	8	15.5	28	500	54
GN.34727	GN 607.5-8-18-ST		8	12	31	25	20	18	54	2	6.5	8	15.5	28	500	59

